

Standard Features

- ▶ Power-Suppress™ 100, 250-2.4kVA
- ▶ Power-Suppress™ 100, 1.8kVA-7.5kVA



Power-Suppress™ 100

*Ultra-Isolator
Noise Suppression
Isolation Transformer*

Installation and User Manual

IMPORTANT SAFETY INSTRUCTIONS

SAVE THESE INSTRUCTIONS – This manual contains important instructions for the Power-Suppress™ 100 that must be followed during operation of the equipment.



WARNING

Opening enclosures expose hazardous voltages. Always refer service to qualified personnel only.

ATTENTION

L'ouverture des cabinets expose des tensions dangereuses. Assurez-vous toujours que le service ne soit fait que par des personnes qualifiées.

WARNUNG!

Das Öffnen der Gehäuse legen gefährliche Spannungen bloss. Service sollte immer nur von qualifizierten Personal durchgeführt werden.



WARNING

As standards, specifications, and designs are subject to change, please ask for confirmation of the information given in this publication.

ATTENTION

Comme les normes, spécifications et produits peuvent changer, veuillez demander confirmation des informations contenues dans cette publication.

WARNUNG!

Normen, Spezifizierungen und Pläne unterliegen Änderungen. Bitte verlangen Sie eine Bestätigung über alle Informationen, die in dieser Ausgabe gemacht wurden.



NOTE

This equipment has been tested and found to comply with the limits for a Class A digital device, pursuant to part 15 of the FCC rules. These limits are designed to provide reasonable protection against harmful interference when the equipment is operated in a commercial environment.

This equipment generates, uses, and can radiate radio frequency energy and, if not installed and used in accordance with the instruction manual, may cause harmful interference to radio communications. Operation of this equipment in a residential area is likely to cause harmful interference in which case the user will be required to correct the interference at user's own expense.

Certification Standards

- ▶ ANSI/IEEE C57.12.91 Standards
- ▶ IEEE C62.41 cat.A3
- ▶ NFPA 70 – National Electrical Code
- ▶ FCC rules and regulations of Part 15, Subpart J, Class A
- ▶ UL listed under 1012, Power Supplies - General Purpose
- ▶ NEMA PE 1 (National Electrical Manufacturers Association)
- ▶ NEMA 250 (National Electrical Manufacturers Association)
 - Enclosures for Electrical Equipment (1000 Volts Maximum)
- ▶ ISO 9001
- ▶ Occupational Safety & Health Administration (OSHA)



WARNING To reduce the risk of fire or electric shock, install in a temperature and humidity controlled indoor area free of conductive contaminants.

This equipment is intended only for installations in a **RESTRICTED ACCESS LOCATION**.

ATTENTION Pour réduire le risque d'incendie ou d'électrocution, installer dans une enciente intérieure contrôlée en température et humidité et sans contaminants conducteurs.

Ce matériel est destiné seulement pour des installations dans un **EMPLACEMENT RESTREINT d'accès**.

WARNUNG! Um die Gefahr von Feuer und elektrischem Schock zu reduzieren, muss das Gerät in einem temperatur – und feuchtigkeitskontrollierten Raum, frei von leitungsfähigen Verunreinigungen, installiert werden. Dieses Gerät ist nur für die Installation an einem Ort mit eingeschränkter Zugangserlaubnis vorgesehen.

Diese Ausrüstung ist nur für Anlagen in einem **EINGESCHRÄNKTEN ZUGRIFF STANDORT** bestimmt.



WARNING **HIGH LEAKAGE CURRENT.** Earth connection essential before connecting supply.

ATTENTION **COURANT DE FUITE ELEVE.** Raccordement a la terre indispensable avant le raccordement au reseau.

WARNUNG! **Hoher Ableitstrom Vor Inbetriebnahme Schutzleiterverbindung herstellen.**

How to use this manual and Symbol Usage

This manual is designed for ease of use and easy location of information.

Locate specific topics in the Table of Contents.

For terms used in the text refer to the Glossary.

Typographical conventions use “< >” angle brackets in procedures to denote a prompt for User action.

For example: 1. After the selections are complete, click on the <Save> button.

This manual uses four icon symbols with text to convey important information and tips.



WARNING Indicates information provided to protect the user and service personnel against safety hazards and/or possible equipment damage.



CAUTION Indicates information provided to protect the user and service personnel against possible equipment damage.



IMPORTANT Indicates information provided as an operating instruction, or as an operating tip.



NOTE Indicates information provided as an operating tip or an equipment feature.

CAUTION: Record All Serial Numbers!

**RECORD ALL SERIAL NUMBERS FOR THE Power-Suppress™ 100 AND COMPONENTS.
THESE SERIAL NUMBERS WILL BE REQUIRED IF YOUR SYSTEM NEEDS SERVICE.
KEEP THIS MANUAL IN A PLACE WHERE YOU CAN REFERENCE THE SERIAL
NUMBERS IF SERVICE IS REQUIRED!**

Power-Suppress™ 100 Unit SERIAL NUMBER: _____

ADDITIONAL SERIAL NUMBERS:

_____	_____
_____	_____
_____	_____
_____	_____
_____	_____
_____	_____
_____	_____
_____	_____
_____	_____
_____	_____
_____	_____

Power-Suppress™ 100

Ultra-Isolator
Noise Suppression
Isolation Transformer

Installation and User Manual

Revision History

Product: *Installation and User Manual* 86-109608-00 D00

Revision:	A00	Initial Release	06/2003
	B00	ECN#: 003465	08/2003
	C01	ECN#: 003588	09/2003
	D00	ECN#: 004869	08/2006
	D01	ECN#: 005067	12/2006

Copyright © 2007 MGE Office Protection Systems
All rights reserved. Printed in U.S.A.

MGE Office Protection Systems
13 Whatney, Suite #101
Irvine, CA 92618
(949) 268-2800

For Technical Support, Customer Care Center, or Customer FAQ,
please visit our website: www.mgeops.com or call (800) 279-7776

M G E

Office Protection Systems



(This page left blank intentionally)

section	description	page
	IMPORTANT SAFETY INSTRUCTIONSii
	Certification Standardsii
	How to use this manual and Symbol Usageiii
	CAUTION: Record All Serial Numbers!iv
	Revision Historyv

Section 1 Introduction

section	description	page
1.0	Scope1 – 1
1.1	Reference Manuals1 – 1
1.2	Section Descriptions1 – 1
1.3	Receiving1 – 1
1.3.1	Location and Storage1 – 2
1.4	Prerequisites to Installation1 – 3
1.5	General Description1 – 3
1.5.1	Electrical Specifications1 – 3
1.5.2	Environmental Specifications1 – 3
1.5.3	Mechanical Specifications1 – 4
1.5.4	Cabinet Dimensions1 – 4

Section 2 Installation

section	description	page
2.0	Scope2 – 1
2.1	Installation Notes2 – 1
2.2	Installation of Hardwired Models2 – 1
2.2.1	Changing the Input or Output Voltage2 – 1

Section 3 Maintenance

section	description	page
3.0	Scope3 – 1
3.1	Preventive Maintenance3 – 1
3.2	Troubleshooting3 – 1

MGE Office Protection Systems Customer Care Center

Technical Support and Product Services
Who To Contact
Scheduling Field Service Engineer Support
Return Policy for Repair (RMA)

Glossary G — 1

Reorder Form RO—1

Figures

figure	description	page
1-1:	Vertical Mounting Drawing.	1 — 2
1-2:	250VA-1kVA Isolation Transformer Enclosure.	1 — 5
1-3:	250VA-1kVA Isolation Transformer Hardwired Enclosure.	1 — 5
1-4:	1.8kVA Isolation Transformer Enclosure.	1 — 6
1-5:	2.4kVA Isolation Transformer Enclosure.	1 — 6
1-6:	1.8kVA-7.5kVA Isolation Transformer Hardwired Enclosure.	1 — 7
2-1:	Wiring Diagram for 250VA-1000VA 120VAC Input.	2 — 3
2-2:	Wiring Diagram for 1800VA-2400VA 120VAC Input.	2 — 3
2-3:	Circuit Diagram for 250VA-1000VA 240/120VAC Input.	2 — 4
2-4:	Circuit Diagram for 1800VA-7500VA 240/120VAC Input.	2 — 5

Tables

table	description	page
1-1:	Cabinet Standard Dimensions and Weights with Plugs and Receptacles	1 — 4
1-2:	Cabinet Standard Dimensions and Weights, Hardwired.	1 — 4
2-1:	Terminal Block Wire Range and Torque Specifications.	2 — 1

1.0 Scope

Introduction is a general description of system characteristics of the product, its intended use and applicable electrical, mechanical and environmental specifications, voltage requirements, AC input and circuit breaker readings.

1.1 Reference Manuals

N/A

1.2 Section Descriptions

This manual is divided into three sections:

Section 1 Introduction

This section is a general description of the Power-Suppress™ 100 Ultra-Isolator. This includes receiving, electrical, mechanical specifications, and cabinet measurements.

Section 2 Installation

This section guides the User through installation requirements, wire, and circuit diagrams, hardwired connections, and factory configuration ratings for the Power-Suppress™ 100.

Section 3 Maintenance and Troubleshooting

This section contains preventive maintenance for the Power-Suppress™ 100 units, and a troubleshooting guide to assist the User with any communication and configuration connections.

A Glossary in the rear of this manual provides definitions of terms used within the text.

1.3 Receiving

Before accepting the shipment from the freight carrier, inspect the exterior surfaces of all shipping containers or packaging used, and the equipment, for damage that may have occurred during transit. If the shipping containers or equipment shows evidence of damage, note the damage on the receiving document (bill of lading) prior to signing for receipt of equipment.

ALL CLAIMS FOR SHIPPING DAMAGE MUST BE FILED DIRECTLY WITH THE CARRIER. Replacements for damaged components should be ordered through MGE Office Protection Systems.

Check by thorough inspection if any electrical connections have become loose because of vibration during shipment. Check the nameplate to be sure that the voltage and frequency match the available power supply. Under no circumstance should the unit be connected to a power source which does not conform to the nameplate rating.

1.3.1 Location and Storage

The unit is convection cooled with the air vents located on the sides and top of the unit enclosure. Therefore, it should be installed in a clean, dry place with enough clearance to allow a free flow of air. Allow at least 4 inches of space between the unit and the wall or other equipment for portable units. Allow enough space for maintenance on all four sides on larger units. Never mount one unit over the other, heat rising from the unit may cause premature failure. Never install the unit near a heat source.



NOTE: If the unit is to be mounted vertically, the surface area must be capable of supporting at least 4 times the unit's weight. (See Table 1-2, page 1-4.) Locate the conduit knockouts at the bottom, with the mounting slots in the mounting brackets facing down. Transfer the hole pattern from the unit to the mounting surface and drill the holes, refer to dimensions, page 1-5 and 1-7 for hardwire enclosure. Use at least .25" hardwire (minimum grade 5) to attach the unit to the surface, with 6.00" clearance around the unit for air flow.

If the equipment is to be stored prior to installation, it should be stored in a cool, dry, well-ventilated location that is protected from rain, splashing water, chemical agents, etc. The equipment should be covered with a tarpaulin or plastic wrapper to protect it against dust, dirt, paint, or other foreign materials.

Figure 1-1: Vertical Mounting Drawing.

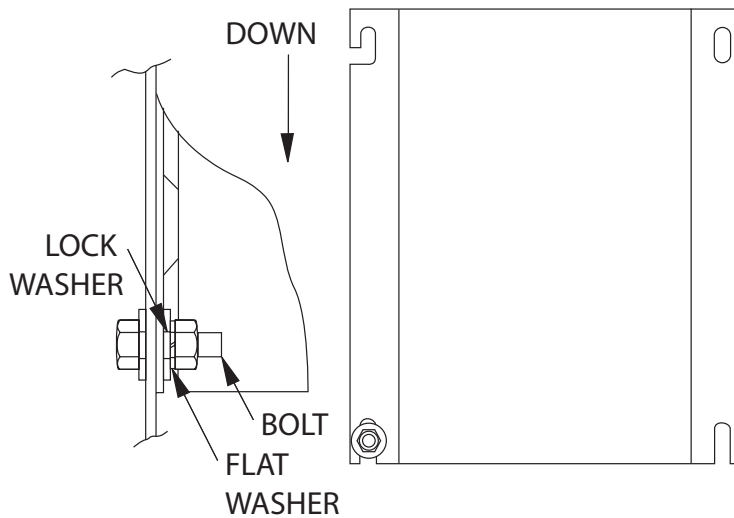

1.4 Prerequisites to Installation

An efficient installation depends on careful planning and site preparation. Installation of the equipment must be handled by skilled technicians and electricians familiar with the special requirements of high-voltage electrical equipment. The installation must comply with the requirements of the National Electrical Code (ANSI/NFPA 70, latest issue) and local codes as applicable, and safety standard, UL1012 listed; UL1449 compliant; meets FCC Cat. A.

1.5 General Description

The overall function of the Power-Suppress™ 100 is to attenuate transients and noise that originate on the incoming power lines and provide a newly derived, isolated power source.

The Power-Suppress™ 100 is used to protect sensitive electronic equipment and computers from power line noise and transients. There are common disturbances on the power lines caused by lightning, motor starting and stopping, utility network switching and general electrical noise, which will adversely affect sensitive electronic equipment, especially computers.

The Power-Suppress™ 100 utilizes a unique method of shielding and isolation which provides low capacitive coupling between input and output circuits. This low capacitance, together with a highly effective filter circuit, results in ultra high common mode and normal mode noise attenuation.

1.5.1 Electrical Specifications

Input voltage	120, 240, 480VAC – depending on model
Common mode noise attenuation	140dB @ 100KHz
Normal mode noise attenuation	65dB @ 100KHz
Overload capacity	600% for 1 cycle, 300% for 30 seconds
Dielectric strength	2500 VAC minimum
Frequency	60Hz ± 5%
Impedance	3% to 6%, depending on size
Efficiency	93% to 97%, depending on size
Input voltage range	Nominal voltage ± 10%
Load regulation	2% to 5%, no load to full load at unity power factor
Harmonic distortion	Adds less than 1% THD, under linear loading
Coil insulation	200°C
Temperature Rise	115°C max rise above a 40°C ambient
Electro-magnetic interference	Less than 0.2 gauss @ 3 ft.

1.5.2 Environmental Specifications

Audible noise	Less than 50dB measured @ 3 ft.
Operating temperature	0 to 40°C
Storage temperature	-20° to +50°C
Operating altitude	5,000 ft. (without derating)
Operating humidity	95% relative (non-condensing)

1.5.3 Mechanical Specifications

Rating	Input plug	Output receptacles (NEMA)
250VA – 1kVA	5-15P	5-20R2
1.8kVA	L5-20P	2 x 5-20R2
2.4kVA	L5-30P	2 x 5-20R2

1.5.4 Cabinet Dimensions

Table 1-1: Cabinet Standard Dimensions and Weights with Plugs and Receptacles.

MODEL#	INPUT – OUTPUT VOLTAGES	OUTPUT VA	I/O INTERFACE (NEMA)	W x D x H INCHES	WEIGHT LBS.
T100R-0250	120 - 120	250	5-15P / (1) 5-20R2	6.096 x 12.0 x 6.486	16
T100R-0500	120 - 120	500	5-15P / (1) 5-20R2	6.096 x 12.0 x 6.486	22
T100R-0750	120 - 120	750	5-15P / (1) 5-20R2	6.096 x 12.0 x 6.486	28
T100R-1000	120 - 120	1000	5-15P / (1) 5-20R2	6.096 x 12.0 x 6.486	31
T100R-1800	120 - 120	1800	L5-20P / (2) 5-20R2	11.096 x 17.0 x 10.486	54
T100R-2400	120 - 120	2400	L5-30P / (2) 5-20R2	11.096 x 17.0 x 10.486	58

Table 1-2: Cabinet Standard Dimensions and Weights, Hardwired.

MODEL#	INPUT – OUTPUT VOLTAGES	OUTPUT VA	I/O INTERFACE	W x D x H INCHES	WEIGHT LBS.
T100H-0250	120 / 240 - 120 / 240	250	Hardwired	6.096 x 12.0 x 6.421	16
T100H-0500	120 / 240 - 120 / 240	500	Hardwired	6.096 x 12.0 x 6.421	22
T100H-0750	120 / 240 - 120 / 240	750	Hardwired	6.096 x 12.0 x 6.421	28
T100H-1000	120 / 240 - 120 / 240	1000	Hardwired	6.096 x 12.0 x 6.421	31
T100H-1800	120 / 240 - 120 / 240	1800	Hardwired	11.096 x 17.0 x 10.280	54
T100H-2500	120 / 240 - 120 / 240	2500	Hardwired	11.096 x 17.0 x 10.280	58
T100H-5000	120 / 240 - 120 / 240	5000	Hardwired	11.096 x 17.0 x 10.280	86
T100H-5001	240 / 480 - 120 / 240	5000	Hardwired	11.096 x 17.0 x 10.280	92
T100H-7500	120 / 240 - 120 / 240	7500	Hardwired	11.096 x 17.0 x 10.280	116
T100H-7501	240 / 480 - 120 / 240	7500	Hardwired	11.096 x 17.0 x 10.280	111

Table 1-2 Note: Input and output voltages can be configured for either 120VAC or 240VAC, 240VAC or 480VAC, as indicated above.

Figure 1-2: 250VA-1kVA Isolation Transformer Enclosure.

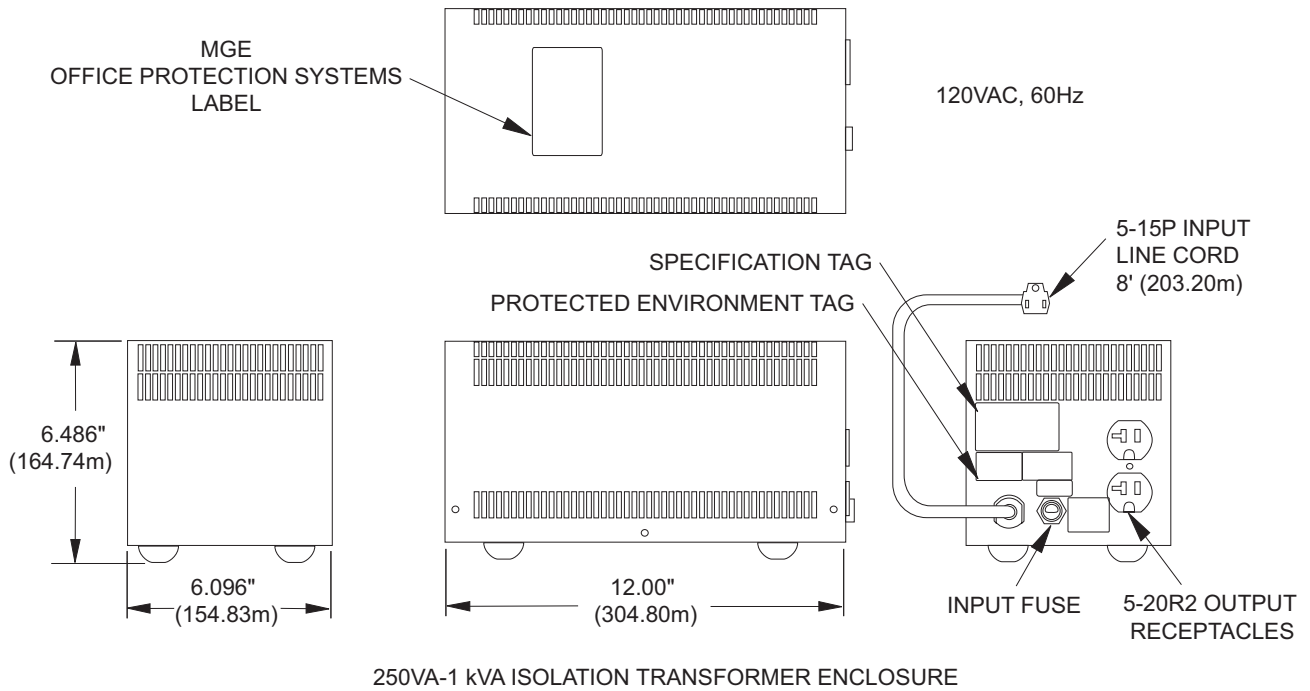
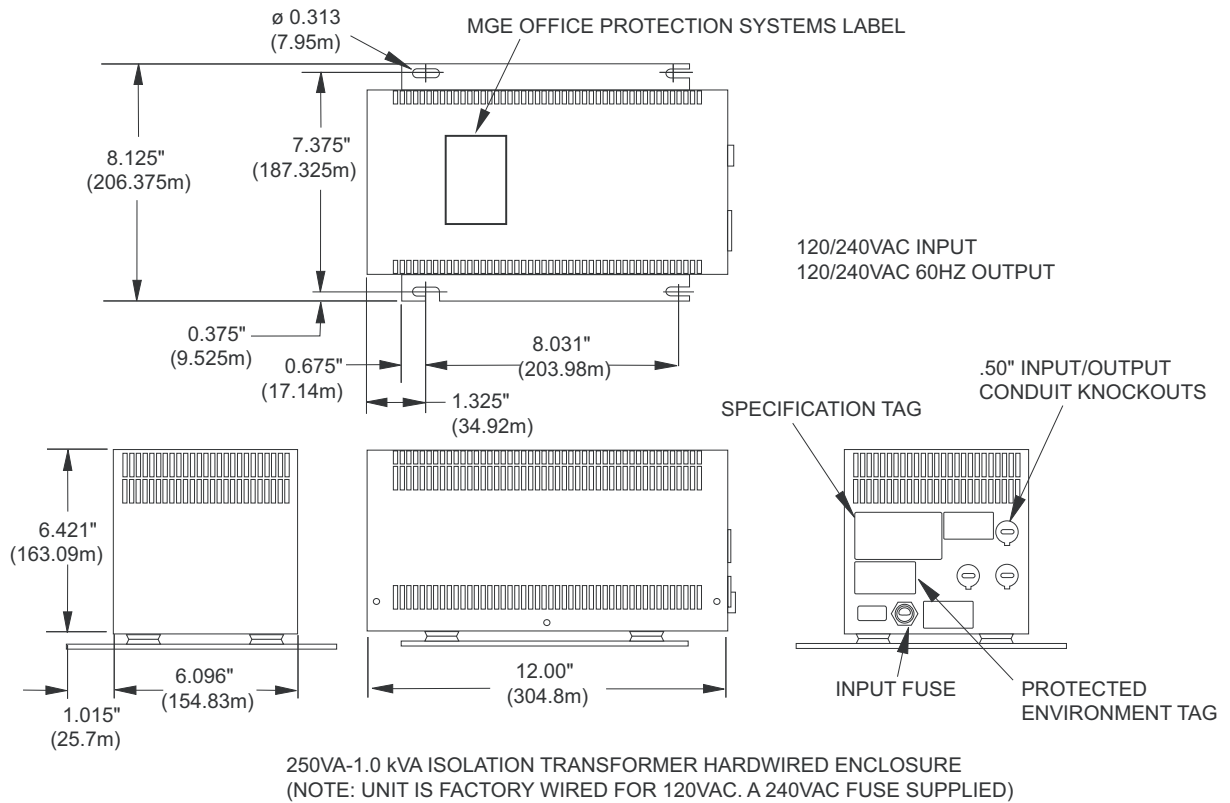

Figure 1-3: 250VA-1kVA Isolation Transformer Hardwired Enclosure.



Power-Suppress™ 100 Ultra-Isolator Transformer

Figure 1-4: 1.8kVA Isolation Transformer Enclosure.

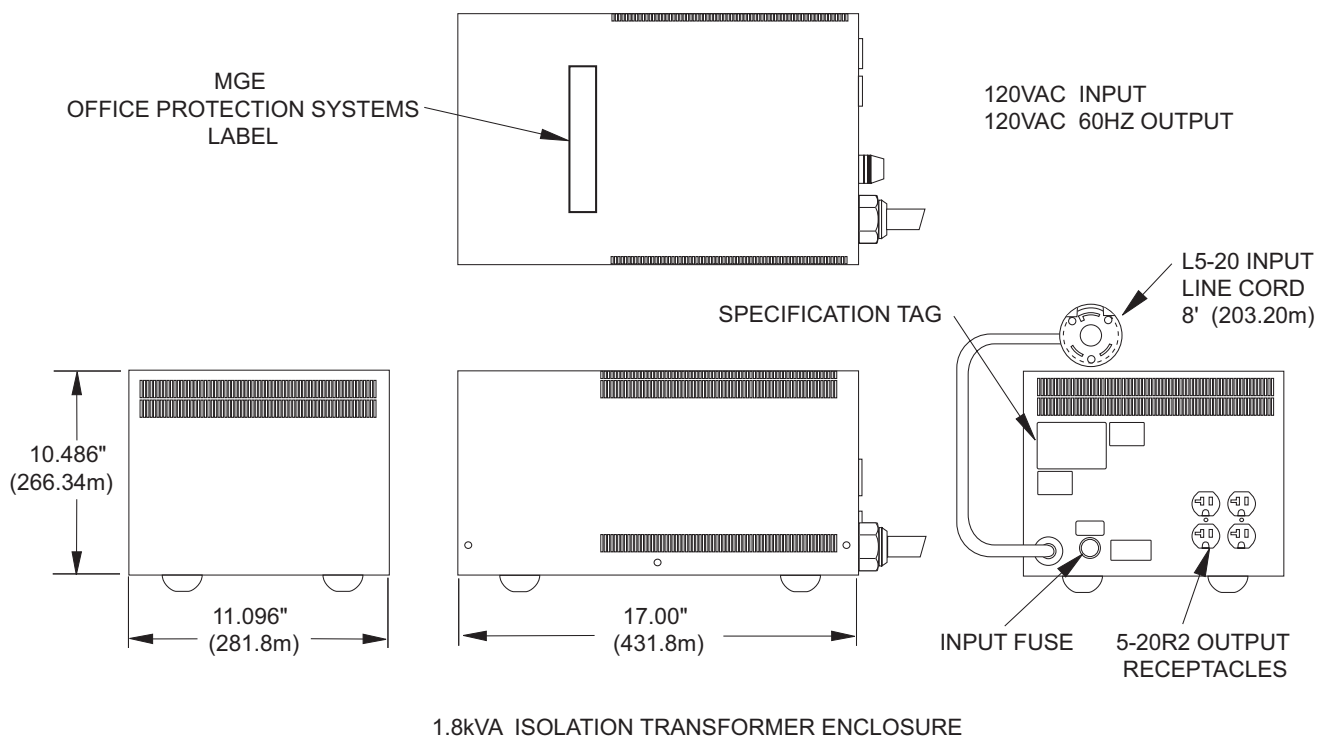

Figure 1-5: 2.4kVA Isolation Transformer Enclosure.

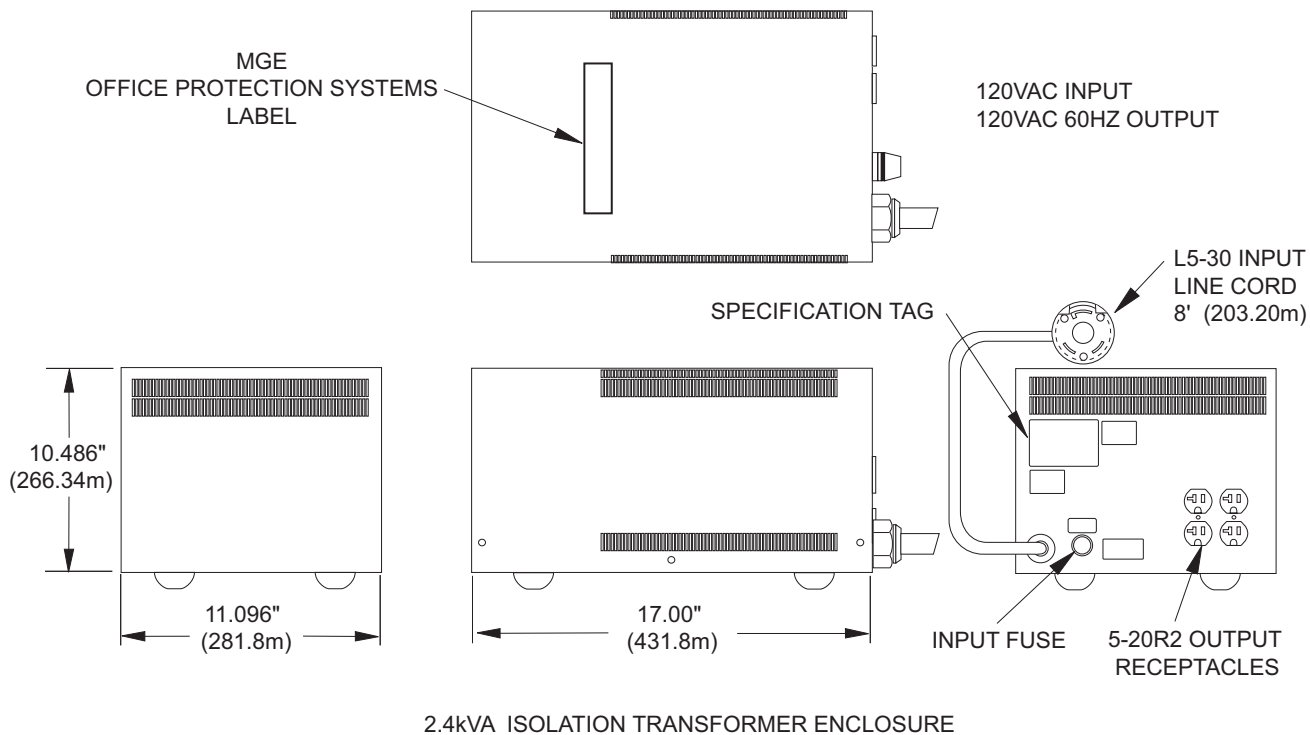
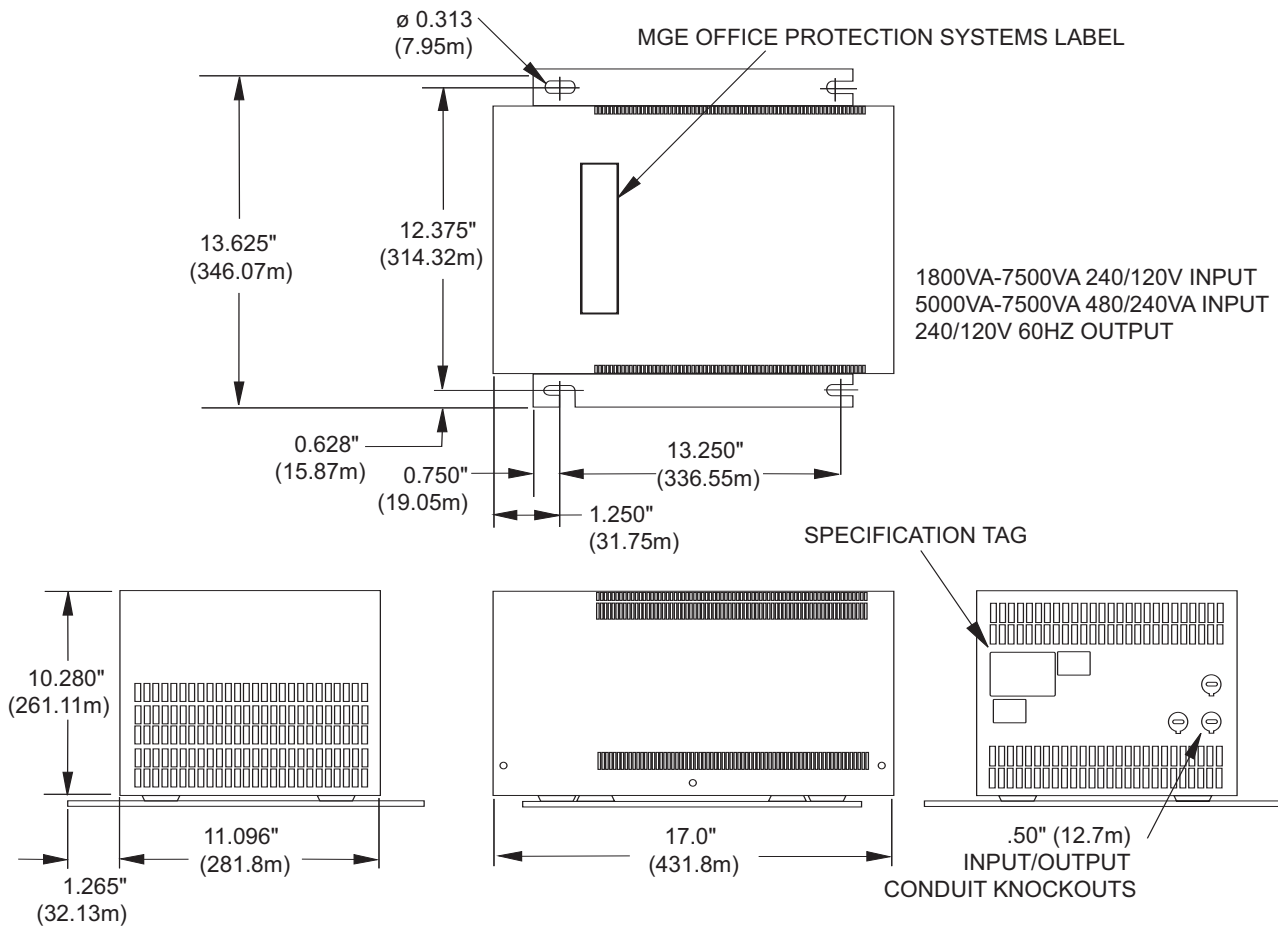

Figure 1-6: 1.8kVA-7.5kVA Isolation Transformer Hardwired Enclosure.



1.8 kVA- 7.5 kVA ISOLATION TRANSFORMER HARDWIRED ENCLOSURE

(This page left blank intentionally)

2.0 Scope

This section guides the User through installation requirements, circuit wiring diagrams, hardwired connections, and factory input/output configurations for the Power-Suppress™ 100.



WARNING: High voltage, only qualified electricians should install or perform maintenance.

2.1 Installation Notes

- ▶ The Power-Suppress™ 100 requires ventilation and should not be mounted in a non-ventilated control cabinet.
- ▶ After installation is complete, verify the output voltage is within its rated specifications.
- ▶ If the Power-Suppress™ 100 is overloaded, the output voltage will drop below its rated specifications and the input fusing will clear.
- ▶ For installation of conduit, reference NEC Article 348 and 350 and any applicable local electrical codes.
- ▶ Power-Suppress™ 100 transformer outputs should not be paralleled.

Refer to Figures 2-1, 2-2, page 2-3, and Figure 2-3, 2-4 page 2-4, for typical wiring diagrams of electrical hookup.

2.2 Installation of Hardwired Models

The Power-Suppress™ 100 Ultra-Isolator is shipped from the factory configured for an input and output of 120VAC, except for 5kVA and 7.5kVA models provided with an input of 240/480VAC, which will be configured for an input of 480VAC and an output of 120VAC.

2.2.1 Changing the Input or Output Voltage

Changing from an input of 120VAC to an input of 240VAC, on models rated at 1000VA and below, requires that the input fuse be changed as indicated. A fuse rated at 240VAC and the correct amperage has been provided with the Power-Suppress™ 100.

Table 2-1: Terminal Block Wire Range and Torque Specifications.

Rating	Wire Range	Tightening Torque
250VA - 1000VA	#20 - #10 AWG	7.0 LB-IN.
1800VA - 7500VA	#18 - #6 AWG	17.7 LB-IN.

1. Reconfiguring the Power-Suppress™ 100 for a different input or output voltage must take place prior to connecting (wiring) the input power source and output (load) conductors. Voltage must not be present at the Power-Suppress™ 100 unit.

2. Verify that the input source voltage is compatible with the input jumper configuration. If not, change input jumper configuration accordingly.
3. Note – Changing from an input of 120VAC to an input of 240VAC, on hardwired models rated at 1000VA and below, requires that the input fuse be changed as indicated. A fuse rated at 240VAC and the correct amperage has been provided with the Power-Suppress™ 100 and is located inside the enclosure, labeled “240VAC fuse”.

In order to access this fuse and configure the Power-Suppress™ 100 input for 240VAC, the units cover must be removed. This is accomplished by removing the (6) screws that hold the cover in place. These screws will be required when re-securing the cover, once the Power-Suppress™ 100 is properly configured.

4. Verify that the output voltage required by the load is compatible with the output jumper configuration. If not, change output jumper configuration accordingly.
5. Once configured properly and making sure power is OFF, connect the input source voltage wires to the terminals provided. Verify connections are tight and energize the unit (Refer to TERMINAL BLOCK WIRE RANGE / TORQUE SPECIFICATION Table 2-1).
6. Verify that the output voltage is within nominal specifications.
7. Turn the power OFF, connected the output (load) wires to the terminals provided. Verify connections are tight, replace the units cover and re-energize the unit (Refer to TERMINAL BLOCK WIRE RANGE / TORQUE SPECIFICATION Table 2-1).
8. 1800VA to 7500VA models configured for an input of 240VAC or 480VAC require a 2 pole input circuit breaker as specified on page 2-5, provided by the customer.
9. All models rated 1000VA or greater require input circuit breaker as specified on page 2-5, provided by the customer.

Figure 2-1: Wiring Diagram for 250VA-1000VA 120VAC Input.

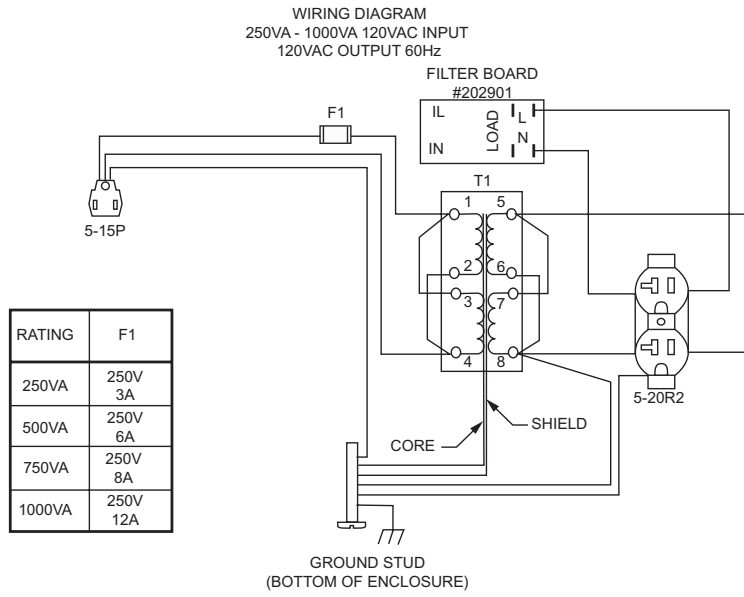
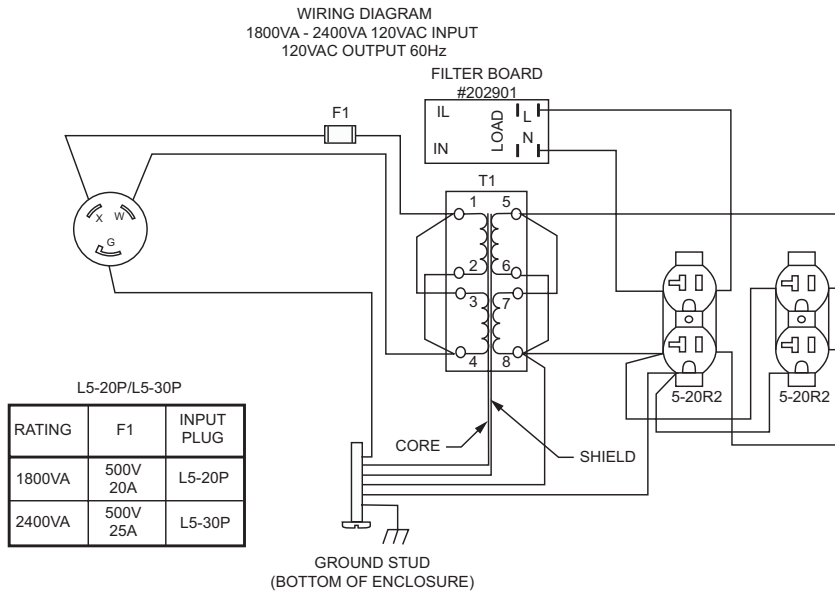
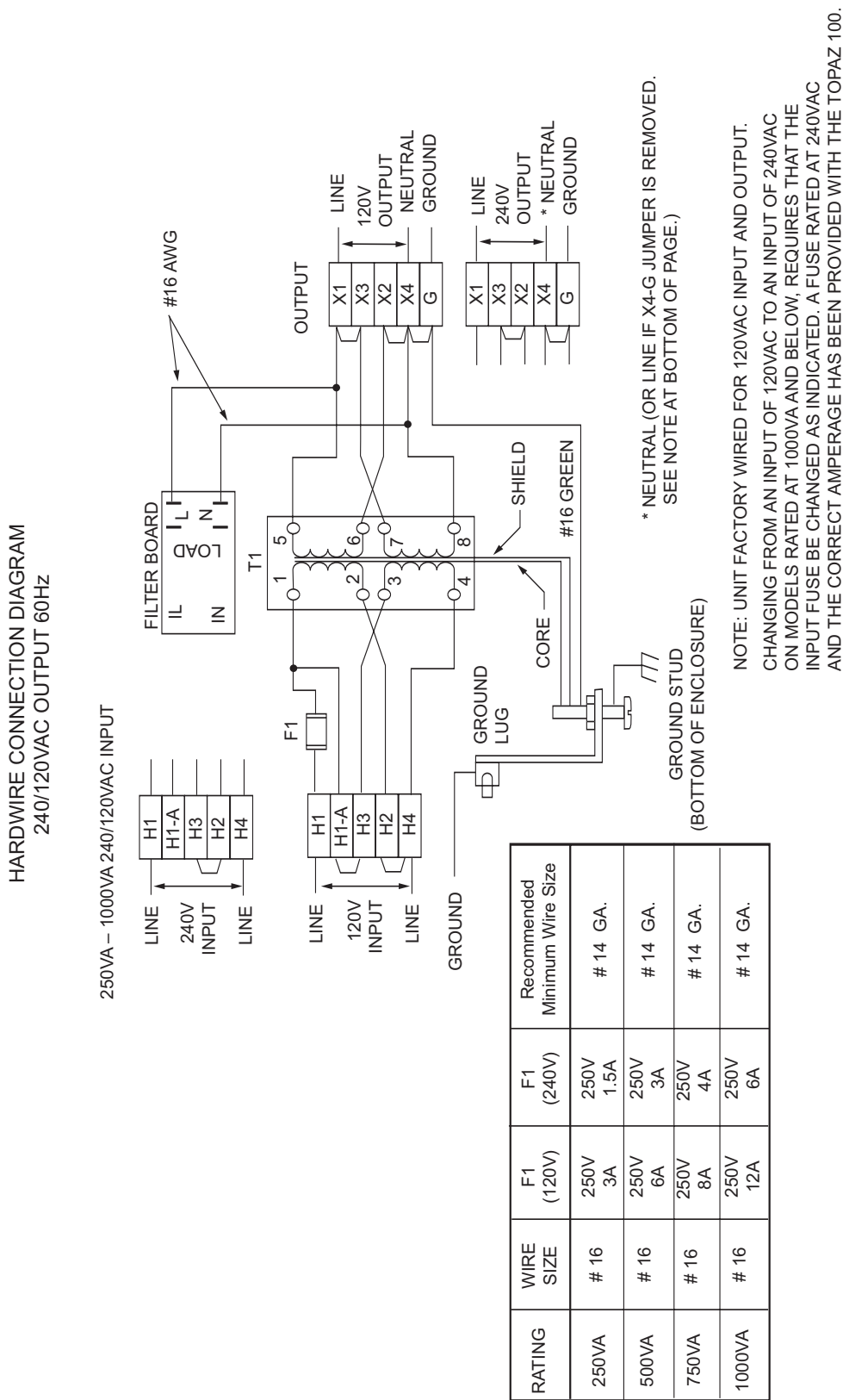

Figure 2-2: Wiring Diagram for 1800VA-2400VA 120VAC Input.



Power-Suppress™ 100 Ultra-Isolator Transformer

Figure 2-3: Circuit Diagram for 250VA-1000VA 240/120VAC Input.



NOTE: IF YOU DESIRE TO HAVE THE OUTPUT NEUTRAL UNGROUNDED, THE BONDING JUMPER CONNECTOR BETWEEN OUTPUT TERMINAL X4 AND GROUND MAY BE REMOVED. NOTE HOWEVER, THAT THIS WILL SIGNIFICANTLY REDUCE THE COMMON-MODE NOISE ATTENUATION OF THE ULTRA-ISOLATOR. REMOVING THIS BOND WILL ALLOW FOR 240VAC LINE TO LINE APPLICATIONS AND PROVIDE ISOLATION.

Figure 2-4: Circuit Diagram for 1800VA-7500VA 240/120VAC Input.

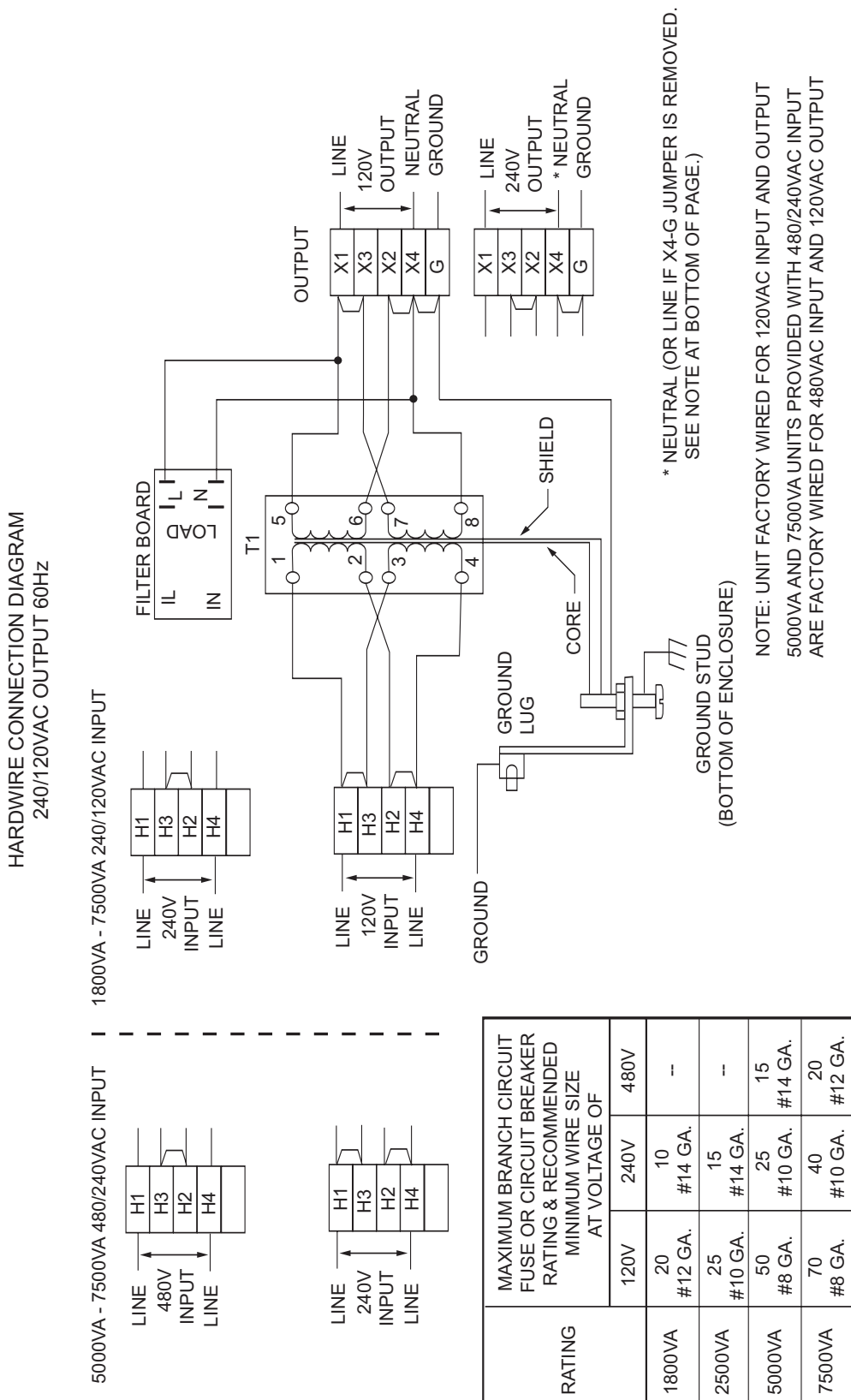

NOTE: IF YOU DESIRE TO HAVE THE OUTPUT NEUTRAL UNGROUNDED, THE BONDING JUMPER CONNECTOR BETWEEN OUTPUT TERMINAL X4 AND GROUND MAY BE REMOVED. NOTE HOWEVER, THAT THIS WILL SIGNIFICANTLY REDUCE THE COMMON-MODE NOISE ATTENUATION OF THE ULTRA-ISOLATOR. REMOVING THIS BOND WILL ALLOW FOR 240VAC LINE TO LINE APPLICATIONS AND PROVIDE ISOLATION.

(This page left blank intentionally)

3.0 Scope

This section contains preventive maintenance for the Power-Suppress™ 100 units, and troubleshooting to assist the User with any communication and configuration connections.



WARNING: HIGH VOLTAGE, ALL POWER MUST BE OFF PRIOR TO ANY MAINTENANCE. ONLY QUALIFIED ELECTRICIANS SHOULD PERFORM MAINTENANCE OR TROUBLE SHOOTING.

3.1 Preventive Maintenance

To ensure longer component life and trouble free operation, minor preventive maintenance procedures should be performed at regular intervals, for example once every year. More frequent inspection intervals would be needed for more severe operation conditions.

At each service inspection, remove any dust, dirt or foreign particles. A slight tug should be used to test if there is any loose electrical connections.

3.2 Troubleshooting

Corrective maintenance might have to be performed on any of the three main component types in the Power-Suppress™ 100 Ultra Isolator: Transformer, Filter Card or Input Fuses.

1. Transformers: The transformer is designed with a considerable safety margin. Normally, the only malfunction that can take place is a short to the core. It can be checked easily with an ohmmeter.
2. Filter Card: MOVs can fail open or capacitors can be defective in the open or shorted mode and checked easily with an ohmmeter. Visual inspection may also allow detection of failed components.
3. Input Fuse: The units input fuse can clear (open) due to a fault or overload condition at the output of the unit or in the rare case of a transformer failure. A fuse is easily replaced via the flush mounted fuse holder located on the back of the enclosure. Before replacing a fuse, the load should be removed or disconnected from the unit and a visual inspection inside the unit should take place.

(This page left blank intentionally)

MGE Office Protection Systems Customer Care Center

Technical Support and Product Services



Technical questions? If you encounter a problem while following the instructions in this manual, or have questions about the operation, repair, or servicing of your equipment, please visit our web site www.mgeops.com for complete service information.

To insure that your questions are correctly answered, please obtain the part number, assembly number, and serial number of the unit and include them in any discussions or correspondence.

Part Number: _____

Assembly Number: _____

Serial number: _____

Who To Contact

For Technical Support, Customer Care Center, Customer FAQ please visit our website: www.mgeops.com

Scheduling Field Service Engineer Support

Scheduling of the MGE Office Protection Systems Field Service Engineers typically should be done 7 to 10 days before they are required on-site. If the startup of the UPS is critical to maintaining your schedule, please contact MGE Office Protection Systems, to insure a safe installation and start-up that will maintain the MGE Office Protection Systems warranty and insure smooth performance.

Return Policy for Single Phase Products (RMA)

Should you require factory service for your equipment, contact MGE Office Protection Systems Customer Care Center and obtain a Return Materials Authorization (RMA) prior to shipping your unit. Never ship equipment to MGE Office Protection Systems without first obtaining an RMA number.

For further details please visit our website: www.mgeops.com

Date: _____

RMA Number: _____

Contact Name: _____

(This page left blank intentionally)

Term used	Definition/Meaning
@	At.
/	And/or.
+/-	Plus or Minus.
≤	Equal to or less than.
#	Number.
°C	Degree Celsius.
°F	Degree Fahrenheit.
∅	Phase angle.
Ω	Ohm; unit of resistance.
®	Trade Mark.
2nd	Second.
AC or ac	Alternating current, also implies root-mean-square (rms).
Ambient Temp.	Temperature of surrounding air.
Ambient noise	Acoustical noise of surrounding environment.
ANSI	American National Standard Institute.
AWG	American Wire Gauge.
Breaker	Electrical circuit interrupter.
BTU or Btu	British thermal unit. Defined as the amount of heat required to raise the temperature of one pound of water by 1°F.
Carrier	The company or individual responsible for delivering goods from one location to another.
C	Common.
CB	Circuit breaker.
cm	Centimeter.
dB	Decibels.
Conduit	A flexible or rigid tube enclosing electrical conductors.
C.S.S.	Customer Support Service.
Current rating	The maximum current that a conductor or equipment can carry reliably without damage.
dBA	Decibel Adjusted.
dBrnC	Decibel above reference noise.
Earth ground	A ground circuit that has contact with the earth.

Electrician	Refers to an installation electrician qualified to install heavy-duty electrical components in accordance with local codes and regulations. Not necessarily qualified to maintain or repair electrical or electronic equipment.
Freq.	Frequency.
GND	Ground (safety).
Hz	Hertz, frequency measurement unit, 1Hz is one cycle per second.
I	Current.
IEC	International Electrotechnical Commission.
IEEE	Institute of Electrical and Electronic Engineers.
Input branch circuit	The input circuit from the building power panel to the equipment.
kVA	KiloVolt-Ampere; is equal to 1000 Volt-Ampere.
L	Line.
LCD	Liquid-Crystal Display unit.
LED	Light Emitting Diode.
mA	Milliampere.
MAX.	Maximum.
MCM	Thousand circular mil; standard wire sizes for multiple stranded conductors over 4/0 AWG in diameter. M is from Roman numerical system indicating 1000.
N	Neutral.
NC	Normally close.
NO	Normally open.
NEC	National Electrical Code.
NFPA	National Fire Protection Association.
OSHA	Occupational Safety and Health Agency.
Shipping damage	Any damage done to an article while it is in transit.
SPDT	Single Pole Double Throw.
Technician	Refers to an electronic technician qualified to maintain and repair electronic equipment. Not necessarily qualified to install electrical wiring.
V	Volts.
VA	Volt-amps, unit for apparent power measurement, equal $V \times I$.
VAC or Vac	Voltage of AC type.
Via	By way of.

**Contact MGE Office
Protection Systems**

United States

MGE Office Protection Systems
13 Whatney, Suite #101
Irvine, CA 92618

(949) 268-2800

www.mgeops.com